

DC

# ISOMETER® isoCHA425

Insulation monitoring device for unearthed DC systems  
(IT systems) DC 0 V to 400 V.

Suitable for DC charging stations according to CCS or CHAdeMO



## ISOMETER® isoCHA425

**Insulation monitoring device  
for unearthed DC systems (IT systems) DC 0 V to 400 V.  
Suitable for DC charging stations according to CCS or CHAdeMO**



### Standards and certifications

The ISOMETER® was developed in compliance with the standards specified in the Declaration of Conformity.



### EU Declaration of Conformity

Hereby, Bender GmbH & Co. KG declares that the device covered by the Radio Directive complies with Directive 2014/53/EU. The full text of the EU Declaration of Conformity is available at the following Internet address:



[https://www.bender.de/fileadmin/content/Products/CE/CEKO\\_isoXX425.pdf](https://www.bender.de/fileadmin/content/Products/CE/CEKO_isoXX425.pdf)

### UKCA Declaration of Conformity

Hereby, Bender GmbH & Co. KG declares that this device is in compliance with Radio Equipment Regulations 2017 (S.I. 2017/1206). The full text of the UK declaration of conformity is available at the following internet address:



[https://www.bender.de/fileadmin/content/Products/UKCA/UKCA\\_isoXX425.pdf](https://www.bender.de/fileadmin/content/Products/UKCA/UKCA_isoXX425.pdf)

### Intended use

The ISOMETER® monitors the insulation resistance  $R_F$  for DC fast charging stations according to CHAdeMO standard or according to Combined Charging System (CCS) for nominal system voltage ranges between DC 0 V and 400 V.

In order to meet the requirements of the applicable standards, customised parameter settings must be made on the equipment in order to adapt it to local equipment and operating conditions. Please heed the limits of the range of application indicated in the technical data.

- i** To ensure that the ISOMETER® functions correctly, an internal resistance of  $\leq 1 \text{ k}\Omega$  must exist between L+ and L- via the source (e.g. the transformer) or the load.
- i** If the ISOMETER® is installed inside a control cabinet, the insulation fault message must be audible and/or visible to attract attention.

### Device features

- Monitoring of the insulation resistance  $R_F$  of DC charging stations in accordance with the CHAdeMO standard or Combined Charging System (CCS).
- CHAdeMO (Mode CHd):
  - Maximum system leakage capacitance  $1.6 \mu\text{F}$  per conductor
  - Detection of insulation faults in the system voltage range from 50 V to 400 V
  - Response for time one-pole insulation faults  $R_{FU}$ :
    - $R_{FU} \leq 100 \text{ k}\Omega$ : max. 1 s
    - $100 \text{ k}\Omega < R_{FU} \leq 2 \text{ M}\Omega$ : max. 10 s
  - Response time for two-pole insulation faults  $R_{FS}$ : max. 10 s
- CCS (Mode dc):
  - Detection of insulation faults up to  $2 \text{ M}\Omega$
  - Maximum system leakage capacitance  $C_e$ :  $5 \mu\text{F}$
  - Response time  $t_{an}$  at  $C_e \leq 5 \mu\text{F}$  or  $R_F \leq 100 \text{ k}\Omega$ : max. 10 s
- Measuring the system leakage capacitance  $C_e$
- Measuring the nominal system voltage  $U_n$  (true RMS) with undervoltage/overvoltage detection
- Measuring the residual voltages  $U_{L1e}$  (between L+ and earth) and  $U_{L2e}$  (between L- and earth)
- Selectable start-up delay, response delay and delay on release
- Two separately adjustable response value ranges from  $5 \dots 250 \text{ k}\Omega$  (prewarning, alarm)
- Alarm output via LEDs ('AL1', 'AL2'), display, and alarm relays ('K1', 'K2')
- Automatic device self test with connection monitoring
- Selectable N/C or N/O relay operation
- Measured value indication via multi-functional LC display
- Activatable fault memory
- RS-485 (galvanically isolated) including the following protocols:
  - BMS (Bender measuring device interface) for the data exchange with other Bender devices
  - Modbus RTU
  - IsoData (for continuous data output)
- Password protection against unauthorised changing of parameters
- Stop mode to disable the measuring pulse generator

## Functional description

The ISOMETER® is designed for use in DC charging stations according to CHAdeMo standard or Combined Charging System (CCS) and can be set to the respective mode in the 'SEt' menu via the Mode parameter.

It measures

- the total insulation resistance  $R_{FS}$ ;
- the one-sided insulation resistance  $R_{FU}$ ;
- the system leakage capacitance  $C_e$ ;
- the system voltage  $U_n$  (True RMS) between L+ and L-
- the DC system voltages (residual voltages)  $U_{L1e}$  and  $U_{L2e}$  between L+ as well as L- and earth.

$R_{FS}$  and  $R_{FU}$  are combined to the value  $R_F$ . For  $R_F$  a prewarning and an alarm limit value can be set in the 'AL' menu. The prewarning limit value can only be set higher than the alarm limit value. Reaching or falling below the limit values sets a message. For the measured value  $U_n$  an overvoltage and undervoltage limit value can be enabled and adjusted, the violation of which triggers a message. The limit value messages are only deleted when the respective measured value no longer violates the limit value including the corresponding hysteresis.

All messages generated by the ISOMETER® are signalled via the LEDs 'AL1' and 'AL2'. In the 'out' menu, the messages can be assigned to the alarm relays ('K1', 'K2'). In addition, the operation of the alarm relays (n.o./n.c.) can be configured and the fault memory 'M' can be activated or deactivated. If the fault memory is activated, the alarm relays remain in alarm condition until the reset button 'R' is pressed or the supply voltage  $U_s$  is interrupted.

In the 't' menu, the start-up delay at device start, the response delay and the delay on message release as well as the repetition time of the automatic device self test can be set.

For the RS-485 interface, the protocols BMS, Modbus RTU or isoData are selected in the 'out' menu. The measured values can be read and the parameters of the ISOMETER® can be set via the BMS protocols, e.g. using the BMS Ethernet gateway (COM465IP) and Modbus RTU. If the isoData protocol is selected, the ISOMETER® only sends the measured values, once per second.

The device function can be tested using the test button 'T'.

The device parameters are set via the LC display and via the control buttons on the front panel. This function can be password-protected.

The ISOMETER® can be set to stop mode to deactivate the measuring pulse generator.

## Interface/protocols

The ISOMETER® uses the serial hardware interface RS-485 with the following protocols:

### • BMS

The BMS protocol is an essential component of the Bender measuring device interface (BMS bus protocol). Data transmission generally makes use of ASCII characters.

### • Modbus RTU

*Modbus RTU is an application layer messaging protocol, and it provides master/slave communication between devices that are connected via bus systems and networks. Modbus RTU messages have a 16-bit CRC (cyclic redundant checksum), which guarantees reliability.*

### • IsoData

The ISOMETER® sends an ASCII data string with a cycle of approximately 1 second. Communication with the ISOMETER® in this mode is not possible, and no additional sender may be connected via the RS-485 bus cable.

**i** *The IsoData protocol can be terminated by sending the command 'Adr3' during a transmission pause of the ISOMETER®.*

The parameter address, baud rate and parity for the interface protocols are configured in the 'out' menu.

**i** *With 'Adr = 0', the menu entries baud rate and parity are not shown in the menu and the IsoData protocol is activated. With a valid bus address (i.e. not equal to 0), the menu item 'baud rate' is displayed in the menu. The parameter value '---' for the baud rate indicates the activated BMS protocol. In this case, the baud rate for the BMS protocol is set to 9600 baud. If the baud rate is set unequal to '---', the Modbus protocol with configurable baud rate is activated.*

**Ordering information**

Type	Nominal voltage $U_n$	Art. No	
		Screw terminal	Push-wire terminal
isoCHA425-D4-4	CCS: DC 0...400 V CHAdEMO: DC 50...400 V	B91036395	B71036395

**Accessories**

Description	Art. no.
Mounting clip for screw mounting (1 piece per device)	B98060008

**Dimension diagram XM420**

Dimensions in mm

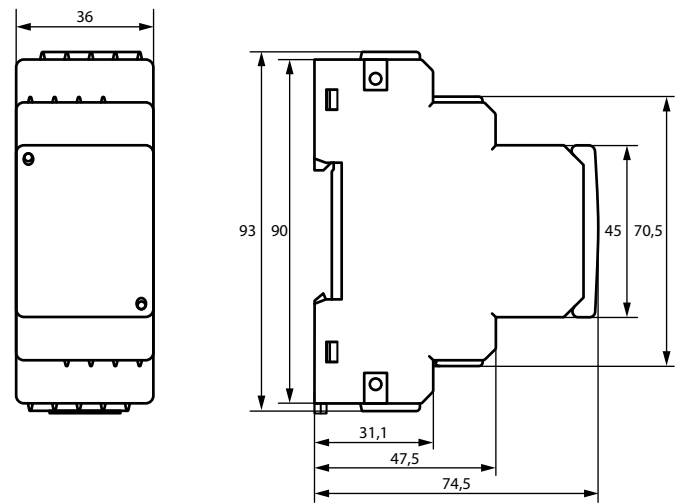

**Operating elements**

Device front	Operating elements	Function
	ON	● Device is running
	AL1	● Prewarning ⊙ Overvoltage
	AL2	● Alarm ⊙ Undervoltage
	▲ ▼	Up and down buttons – For navigating up or down in the menu settings. – For increasing or decreasing values.
	T	Test button (press > 1.5 s)
	R	Reset button (press > 1.5 s)
	↵	Enter button – Select menu item. – Save value.
	MENU	MENU button (press > 1.5 s) – Starts menu mode. – Exits menu item without saving changes.

- LED on
- ⊙ LED flashes

**i** The ,prewarning' and ,alarm' messages can be assigned to the relays

Wiring diagram

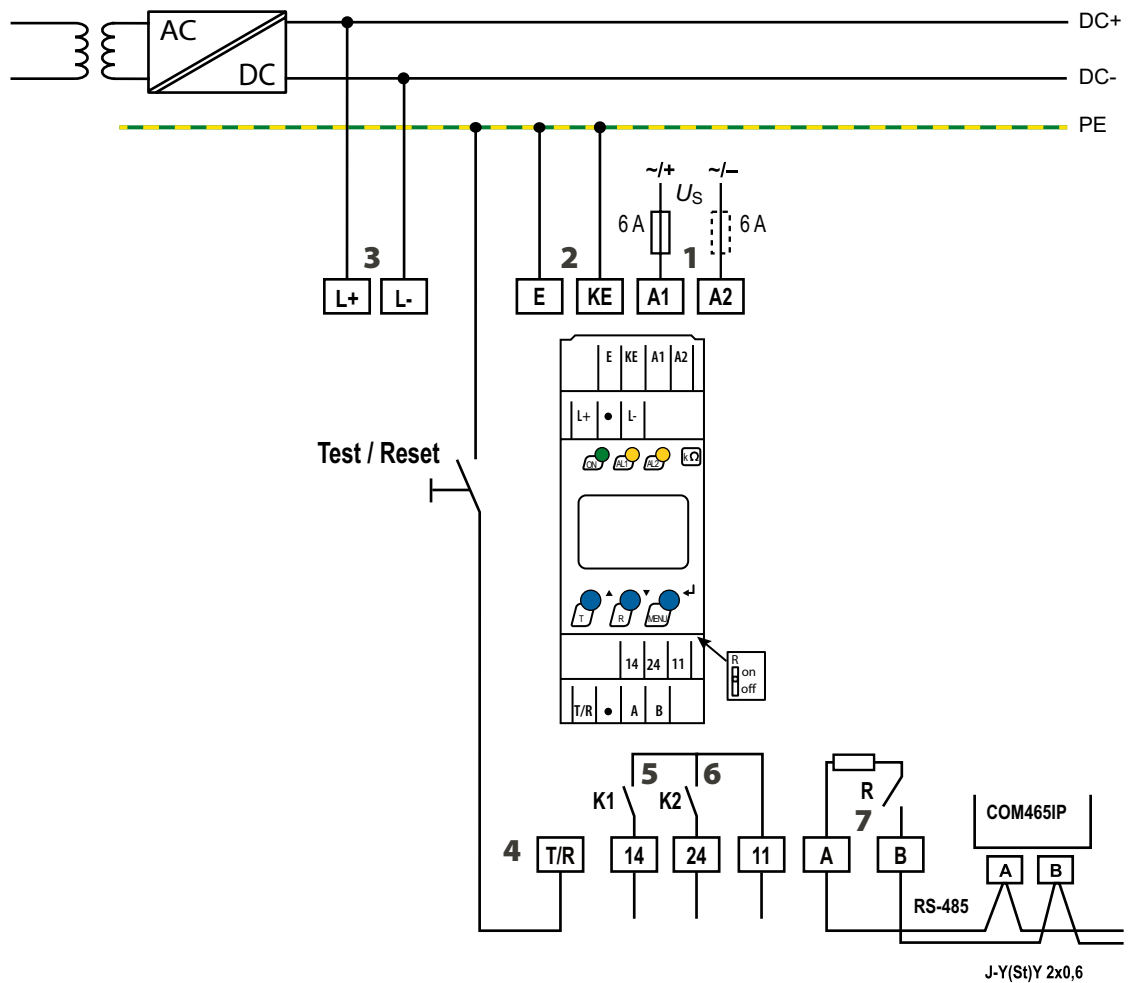

- 1 - A1, A2 Connection to the supply voltage  $U_s$  via fuse (line protection):  
If supplied from an IT system, protect both lines by a fuse.\*
- 2 - E, KE Connect each terminal separately to PE:  
Use same wire cross section as for ,A1', ,A2'.
- 3 - L+, L- Connection to the system to be monitored  
Indication in display: ,L1' for L+; ,L2' for L
- 4 - T/R Connection for the external combined test and reset button
- 5 - 11, 14 Connection to alarm relay ,K1'
- 6 - 11, 24 Connection to alarm relay ,K2'
- 7 - A, B RS-485 communication interface with connectable terminating resistor  
Example: Connection of a BMS Ethernet gateway COM465IP

**i** \* For UL applications:  
Use 60/70 °C copper lines only!  
For UL and CSA applications, using 5 A fuses for the protection of the supply voltage  $U_s$  is mandatory.

## Technical data

### Insulation coordination acc. to IEC 60664-1/-3

Definitions	
Measuring circuit (IC1)	L+, L
Supply circuit (IC2)	A1, A2
Output circuit (IC3)	11, 14, 24
Control circuit (IC4)	E, KE, T/R, A, B
Rated impulse voltage	
IC1/(IC2-4)	6 kV
IC2/(IC3-4)	4 kV
IC3/IC4	4 kV
Rated insulation voltage	
IC1/(IC2-4)	400 V
IC2/(IC3-4)	250 V
IC3/IC4	250 V
Pollution degree	3
Protective separation (reinforced insulation) between	
IC1/(IC2-4)	Overvoltage category III, 600 V
IC2/(IC3-4)	Overvoltage category III, 300 V
IC3/IC4	Overvoltage category III, 300 V
Voltage test (routine test) according to IEC 61010-1	
IC2/(IC3-4)	AC 2.2 kV
IC3/IC4	AC 2.2 kV

### Supply voltage

Supply voltage $U_s$	AC 100...240 V / DC 24...240 V
Tolerance of $U_s$	-30...+15 %
Frequency range $U_s$	47...63 Hz
Power consumption	≤ 3 W, ≤ 9 VA

### IT system being monitored

Nominal system voltage $U_n$	DC 0...400 V
Tolerance of $U_n$	+25 %

### Response values

Response value $R_{an1}$	$R_{an2} \dots 250 \text{ k}\Omega$ (230 k $\Omega$ )*
Response value $R_{an2}$	5 k $\Omega \dots R_{an1}$ (48 k $\Omega$ )*
Hysteresis $R_{an}$	25 %, > 1 k $\Omega$
Undervoltage detection $U$	< 10...499 V (off)*
Overvoltage detection $U$	> 11...500 V (off)*
Overload detection $U$	> 510 V (cannot be deactivated)
Hysteresis $U$	5 %, > 5 V

### System voltage

Measuring range	500 V <sub>RMS</sub>
Display range	0...500 V (measurement True-RMS)
Measurement and relative uncertainty	±5 %, > ±5 V

### Mode CCS (dc)

Permissible system leakage capacitance $C$	≤ 5 $\mu\text{F}$
Measuring and display range $R_F$	1 k $\Omega \dots 2 \text{ M}\Omega$
Measurement uncertainty $R_F$ / relative uncertainty $R_{an}$	±15 %, ±2 k $\Omega$
Measuring and display range $C_e$	0...17 $\mu\text{F}$
Measurement uncertainty $C_e$ :	
$R_F < 10 \text{ k}\Omega$	no measurement
$R_F \geq 10 \text{ k}\Omega$	±15 %, ±0.1 $\mu\text{F}$
Response time $t_{an}$ :	
$R_{an} = 2.0 \times R_F$ and $C_e = 1 \mu\text{F}$ acc. to IEC 61557-8	≤ 10 s
$R_{an} = 2.0 \times R_F$ and $R_F \leq 100 \text{ k}\Omega$	≤ 10 s

### Mode CHAdEMO (CHd)

System voltage $U_n$	measurement from $U_n \geq \text{DC } 50 \text{ V}$
Permissible system leakage capacitance $C_e$	per conductor ≤ 1.6 $\mu\text{F}$
Measuring and display range $R_F$ & $R_{FU}$	1 k $\Omega \dots 2 \text{ M}\Omega$
Measurement uncertainty $R_F$ / relative uncertainty $R_{an}$	±15 %, ±2 k $\Omega$
Measuring and display range $C_e$	0...17 $\mu\text{F}$
Measurement uncertainty $C_e$ :	
$R_F < 10 \text{ k}\Omega$	no measurement
$R_F \geq 10 \text{ k}\Omega$	±15 %, ±0.1 $\mu\text{F}$
Response time $t_{an}$ :	
$R_{an} = 2.0 \times R_{FU}$ and $R_{FU} \leq 100 \text{ k}\Omega$	≤ 10 s
$R_{an} = 2.0 \times R_F$	≤ 10 s

### Displays, memory

Password	off / 0...999 (off / 0)*
Fault memory alarm messages	on/(off)*
Display	LC display, multifunctional, not illuminated

### Time response

Start-up delay $t$	0...10 s (0 s)*
Response delay $t_{on}$	0...99 s (0 s)*
Delay on release $t_{off}$	0...99 s (0 s)*

### Interface

Interface / protocol	RS-485 / BMS, Modbus RTU, isoData
Baud rate	BMS (9.6 kbit/s), Modbus RTU (selectable), isoData (115.2 kbit/s)
Cable length (9.6 kbit/s)	≤ 1200 m
Cable: twisted pairs	min. J-Y(St)Y 2 x 0.6
Terminating resistor	120 $\Omega$ (0.25 W), internal, can be connected
Device address, BMS bus, Modbus RTU	3...90 (3)*

### Switching elements

Switching elements	2 x 1 N/O contact, common terminal 11
Operating principle	N/C operation, N/O operation (N/C operation)*
Electrical endurance under rated operating conditions	10,000 cycles

### Contact data acc. to IEC 60947-5-1

Utilisation category	AC-12 / AC-14 / DC-12 / DC-12 / DC-12
Rated operational voltage	230 V / 230 V / 24 V / 110 V / 220 V
Rated operational current	5 A / 2 A / 1 A / 0.2 A / 0.1 A
Minimum contact load	1 mA at DC ≥ 5 V

### Contact data acc. to UL 508

Rated operational voltage	AC 250 V
Rated operational current	2 A

### Environment/EMC

EMC	IEC 61326-2-4; IEC 61851-21-2:2018-04 Ed. 1.0
-----	---

### Ambient temperatures

Operation	-40...+70 °C <sup>1)</sup>
Transport	-40...+85 °C
Storage	-40...+70 °C

<sup>1)</sup> Below -25 °C the readability of the display is limited.

### Classification of climatic conditions acc. to IEC 60721

(related to temperature and relative humidity)	
Stationary use (IEC 60721-3-3)	3K22
Transport (IEC 60721-3-2)	2K11
Long-term storage (IEC 60721-3-1)	1K22

### Classification of mechanical conditions acc. to IEC 60721

Stationary use (IEC 60721-3-3)	3M11
Transport (IEC 60721-3-2)	2M4
Long-term storage (IEC 60721-3-1)	1M12

---

**Connection**

---

**Screw terminals**

Nominal current	≤ 10 A
Tightening torque	0.5...0.6 Nm (5...7 lb-in)
Conductor sizes	AWG 24...12
Stripping length	8 mm
Rigid / flexible	0.2...2.5 mm <sup>2</sup>
Flexible with ferrules with/without plastic sleeve	0.25...2.5 mm <sup>2</sup>
Multiple conductor rigid	0.2...1.5 mm <sup>2</sup>
Multiple conductor flexible	0.2...1.5 mm <sup>2</sup>
Multiple conductor with ferrules without plastic sleeve	0.25...1.5 mm <sup>2</sup>
Multiple conductor flexible with TWIN ferrules with plastic sleeve	0.25...1.5 mm <sup>2</sup>

**Push-wire terminals**

Nominal current	≤ 10 A
Cross section	AWG 24...14
Stripping length	10 mm
Rigid	0.2...2.5 mm <sup>2</sup>
Flexible without ferrules	0.75...2.5 mm <sup>2</sup>
Flexible with ferrules with/without plastic sleeve	0.25...2.5 mm <sup>2</sup>
Multi-conductor flexible with TWIN ferrules with plastic sleeve	0.5...1.5 mm <sup>2</sup>
Opening force	50 N
Test opening	Ø 2.1 mm

**Other**

Operating mode	continuous operation
Mounting	cooling slots must be ventilated vertically
Degree of protection, built-in components (DIN EN 60529)	IP30
Degree of protection, terminals (DIN EN 60529)	IP20
Enclosure material	polycarbonate
DIN rail mounting acc. to	IEC 60715
Screw mounting	2 x M4 with mounting clip
Documentation number	D00352
Weight	≤ 150 g

( )\* = factory setting



**Bender GmbH & Co. KG**

Londorfer Straße 65  
35305 Grünberg  
Germany

Tel.: +49 6401 807-0  
info@bender.de  
www.bender.de



© Bender GmbH & Co. KG, Germany  
Subject to change!  
The specified standards take into account the  
edition valid until 08.2023 unless otherwise  
indicated.