

Product overview

The power in electrical safety



Design the future
of energy



Table of contents

ISOMETER® insulation monitoring devices for unearthed power supplies (IT systems)	6
ISOSCAN® insulation fault location system for unearthed power supplies (IT systems)	8
LINETRAXX® measuring and monitoring relay for earthed power supplies (TN and TT systems)	10
LINETRAXX® power quality and energy measurement for transparency in electrical installations	12
LINETRAXX® residual current monitors for earthed power supplies (TN and TT systems)	14
LINETRAXX® residual current monitoring systems for earthed power supplies (TN and TT systems)	16
LINETRAXX® modular residual current device MRCD	18
MEDICS® The comprehensive safety solution for medical facilities	20
ATICS® transfer switching and monitoring devices	22
UNIMET® test systems	24
COMTRAXX® system components central display, alarm indicator and operator panels	26
Charging technology for electric and hybrid vehicles Smart charge controllers for AC charging stations and wallboxes	28
POWERSCOUT®	32
Support during all stages	33
Retrofit	34
Bender. Making your world safe.	35





 BENDER

Electrical safety for man and machine

Bender monitoring systems make a decisive contribution

Safety for man and machine means that a trouble-free power supply and thus uninterrupted operation is guaranteed.

The convincing advantages for operators of electrical systems are

- Higher operational reliability through early detection of possible critical operating and system states
- Comprehensive protection of persons and installations against the risks posed by electrical current
- Increased productivity
- Significant reduction of operating costs
- Time and cost-optimised maintenance

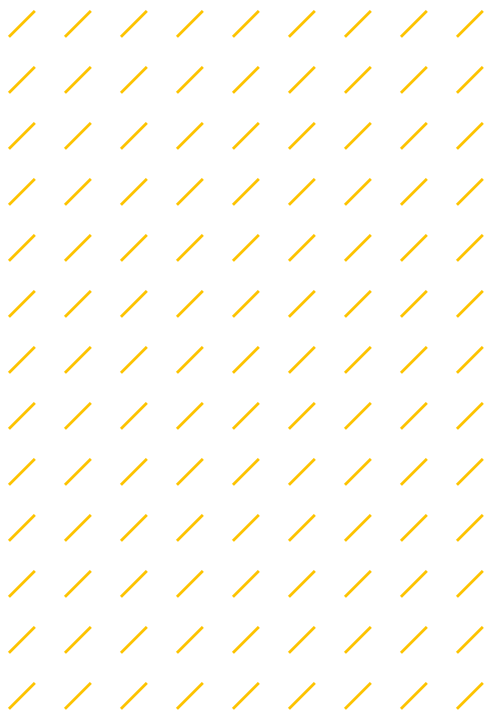

For every application – for every requirement

Maximum electrical safety and trouble-free operating processes are among the central tasks of technical management. As the demand for power quality and operational reliability grows, so do the disruptive factors:

- Moisture
- Ageing
- Temperature
- Chemicals
- Dust
- Mechanical stress
- Mechanical damage
- Overvoltage and undervoltage
- Voltage dips
- Voltage spikes
- Harmonics



Bender monitoring systems are your reliable partners for the checking and maintenance of electrical lines and cables and for power quality monitoring.

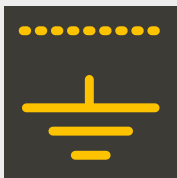

Unearthed power supplies
(IT systems)



Earthed power supplies
(TN and TT systems)

Long-term cost reduction with Bender monitoring systems

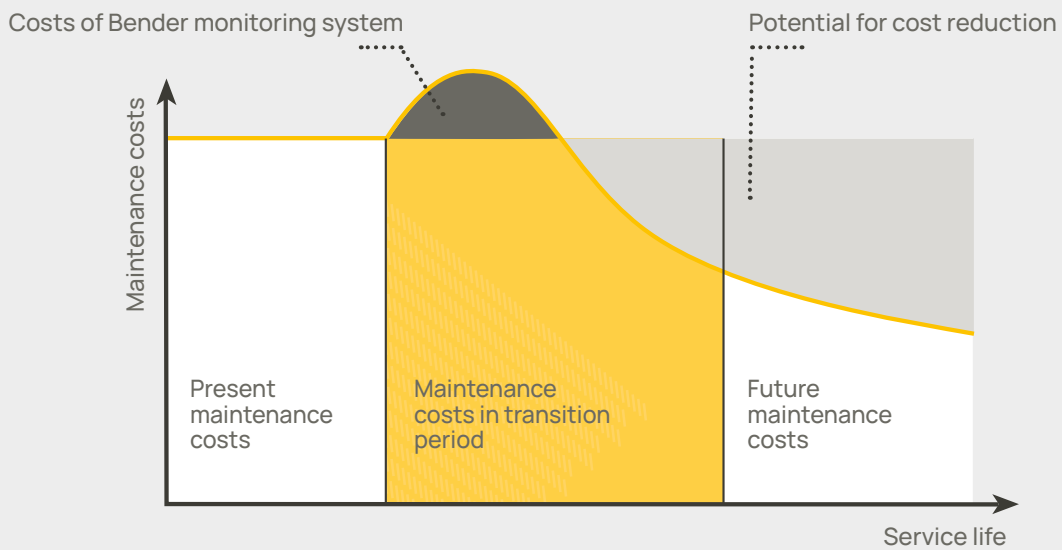

ISOMETER® insulation monitoring devices for unearthed power supplies (IT systems)



Insulation monitoring devices for early signalling of an earth fault in the IT system

Unearthed power supplies have an invaluable advantage – a first earth fault does not lead to shutdown, operating processes are not interrupted.

This is why IT systems with insulation monitoring are used wherever a maximum of safety and reliability is required. The heart of every IT system is the insulation monitoring device ISOMETER®.

Functionality:

The insulation monitoring device ISOMETER® continuously monitors the insulation resistance between system and earth and signals immediately if the measured value has fallen below a certain value. This early information leaves enough time to eliminate the cause of the fault – before a critical operating state occurs!

Typical applications:

- Power supply to production processes
- Control circuits in safety applications
- Variable-speed drives in rolling mills, conveyor systems
- Mobile generators
- Signalling systems in traffic engineering
- Offline loads (pumps, motors)
- Medical facilities
- Control circuits in power plants and transformer stations
- Supply systems on ships
- Photovoltaic systems and much more

Convincing advantages:

- Highest possible level of availability and reliability of the power supply
- Increased protection against fire and accidents
- Precise measurement due to patented AMP measurement method
- Practical solutions for any application
- Significant cost reduction in maintenance and servicing



The heart of every IT system is the insulation monitoring device ISOMETER®

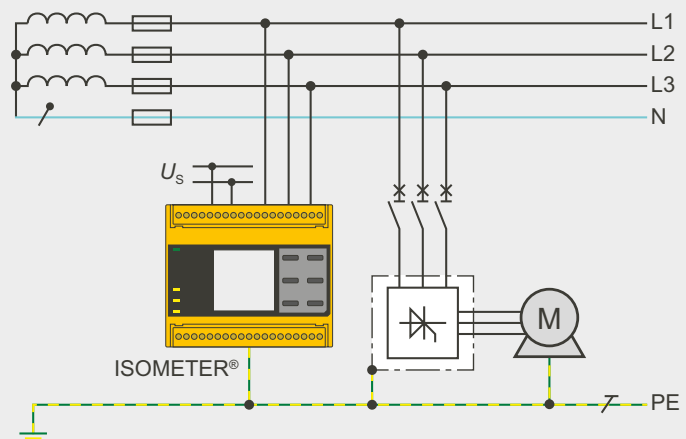

Insulation monitoring in an AC/DC main circuit



Bender solutions make it easy to set up complex and/or coupled systems using the ISONet function to control the measurement authorisation of several iso685 devices. An auxiliary contact of the coupling switches is no longer required.

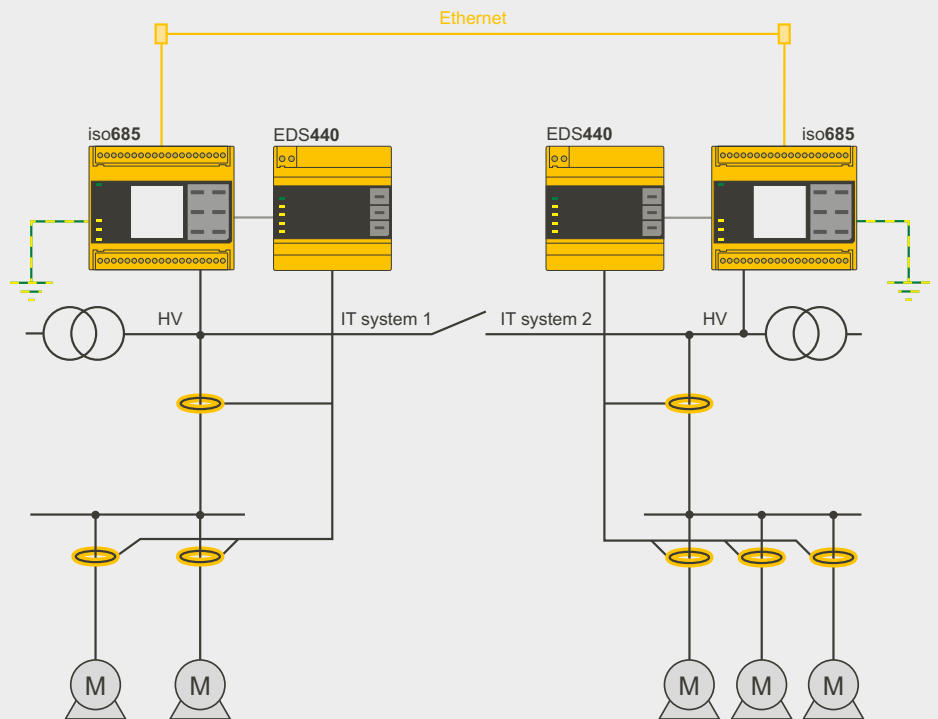

Schematic circuit diagram of standard-compliant insulation monitoring in coupled systems

ISOSCAN® insulation fault location system for unearthed power supplies (IT systems)



Stationary and portable equipment for fast localisation of insulation faults

ISOSCAN® is based on the insulation monitoring device ISOMETER® with integrated locating current injector.

Functionality:

If an insulation fault occurs, insulation fault location starts automatically. The locating current injector generates a locating current signal which flows back via the faulty current path and the PE conductor. All measuring current transformers in this circuit register the locating current signal and report it to the corresponding insulation fault locators.

The assignment of measuring current transformer/ outgoing circuit enables the electrician to locate the fault easily, quickly and safely on screen.

For installations with subordinate outgoing circuits, portable insulation fault location systems are available. Locating current signals are checked with a measuring clamp around the cables of the respective circuits, and the faulty circuit or location is determined.

Convincing advantages:

- Automatic insulation fault location during operation – without disconnection
- Time and cost savings through precise fault location
- Modular design principle for any system
- Central administration via LAN/WLAN network
- Early detection allows planning of repairs

Typical applications:

Main and control circuits

- in industrial installations
- in power plants and transformer stations
- in the food industry
- in medical facilities
- on ships
- on offshore platforms
- in the chemical industry
- in photovoltaic systems
- with railway applications
- Mobile generators
- Edge data centre



Portable insulation fault location system allows fast fault localisation



Insulation monitoring device with integrated locating current injector for insulation fault location



Insulation fault location system

For fast insulation fault location in an IT system, a device for insulation fault location is recommended.

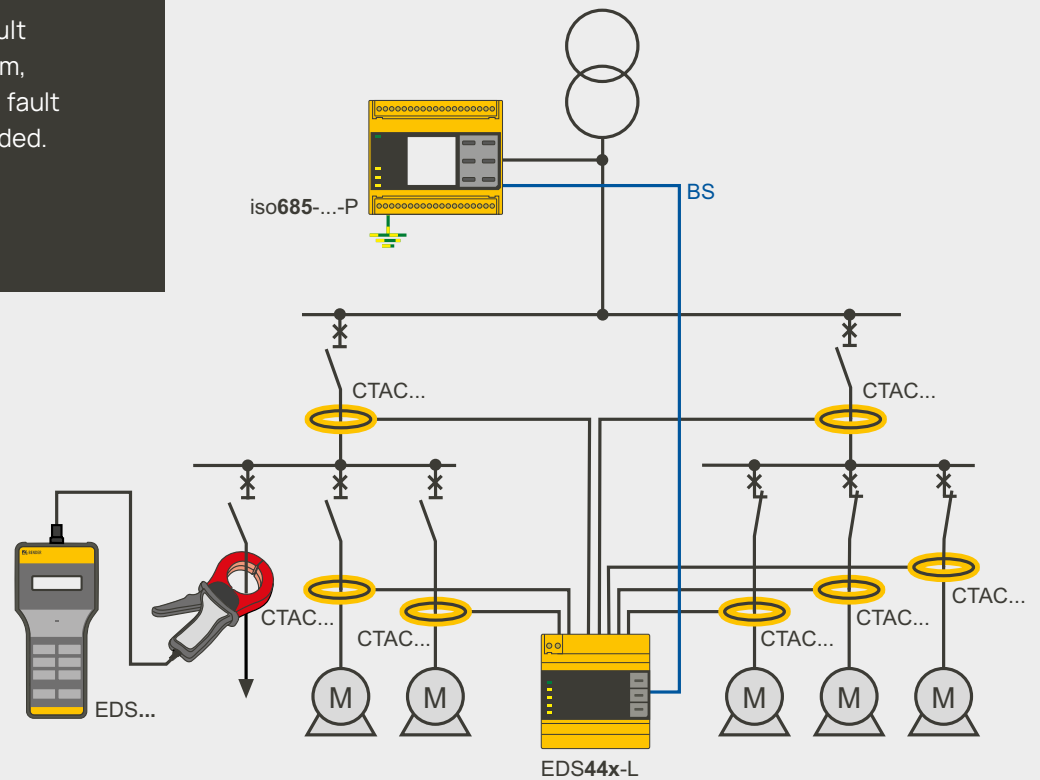

Operating principle of insulation fault location system

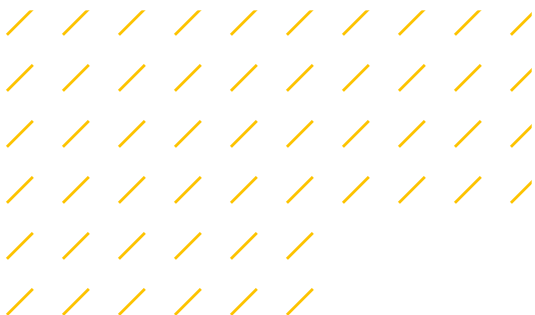

LINETRAXX® measuring and monitoring relays for earthed power supplies (TN and TT systems)



Measuring and monitoring relays for monitoring electrical quantities in electrical installations

Bender measuring and monitoring relays monitor various parameters in main and auxiliary circuits. They provide the necessary information advantage to detect and report faults and malfunctions at an early stage or to shut down immediately in case of critical system states. This reduces interruptions to operation, damage to property and installations, and drastically lowers costs.

Convincing advantages (420 series):

- Two individually adjustable response values/alarm relays
- Analogue interface with nominal signal 4-20 mA/0-10 V
- Automatic pre-parameterisation (preset function)
- Measured value memory with display function for the first tripping value
- Flexible start-up, response and off-delay times
- Continuous self-monitoring
- Password protection for device settings
- Compact design due to 2-module enclosure (36 mm)



VMD423

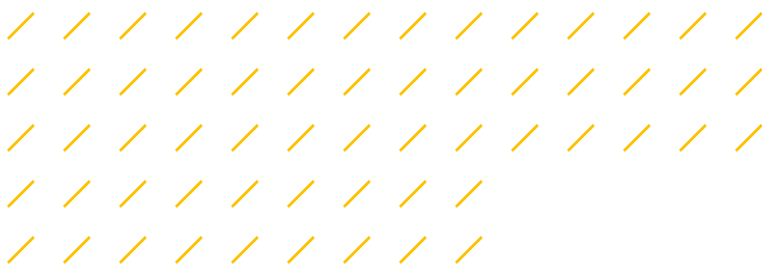

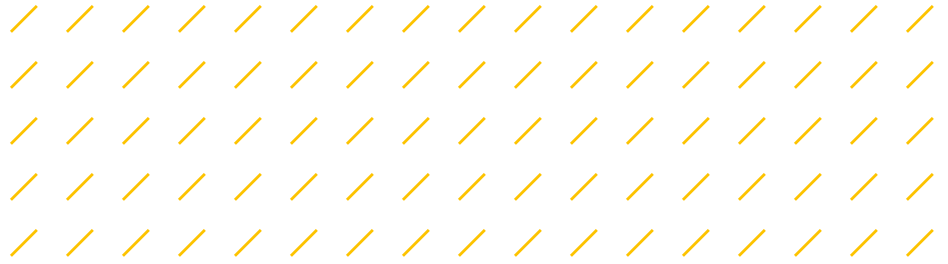

Detecting and reporting faults reliably owing to adjustable response values.



Measuring and monitoring relays

Monitored quantities:

- Voltage
- Current
- Frequency
- Phase sequence
- Phase failure
- Asymmetry
- Loop resistance
- Earth fault
- Vector shift

Typical applications: loop monitoring:

- Loop monitoring for motors
- Loop monitoring in electrical installations for PE conductor interruption
- Monitoring of earthing systems

Typical applications: current monitoring:

- Current consumption of motors, e.g. pumps, elevators, crane systems
- Monitoring of lighting circuits, heating circuits, charging stations
- Monitoring of emergency lighting
- Monitoring of screw conveyors, e.g. in sewage treatment plants

Typical applications: voltage and frequency monitoring:

- Monitoring of voltage sensitive installations
- On and off function above a certain voltage limit
- Monitoring of emergency or standby power supplies
- Monitoring the supply voltage of mobile loads
- Protection of three-phase motors by detection of phase failure and incorrect phase sequence
- Protection of transformers by detecting asymmetrical loads
- Grid decoupling of generation plants (NS protection)

LINETRAXX® power quality and energy measurement for transparency in electrical installations

Acquisition of relevant data for energy management and basic power quality measurands

The PEM digital universal measuring instrument is used to record and display electrical quantities of an electric power supply system. The scope of the measurements ranges from currents and voltages, energy consumption and power up to the total distortion factor for assessing the voltage quality.

Convincing advantages:

The measured data are collected and displayed by the COMTRAXX® condition monitor.

- One platform for uniform operation of and parameter setting for a wide variety of devices
- Intuitive operation



Power quality and energy measurement



Makes network reactions visible - for high availability of your installations.

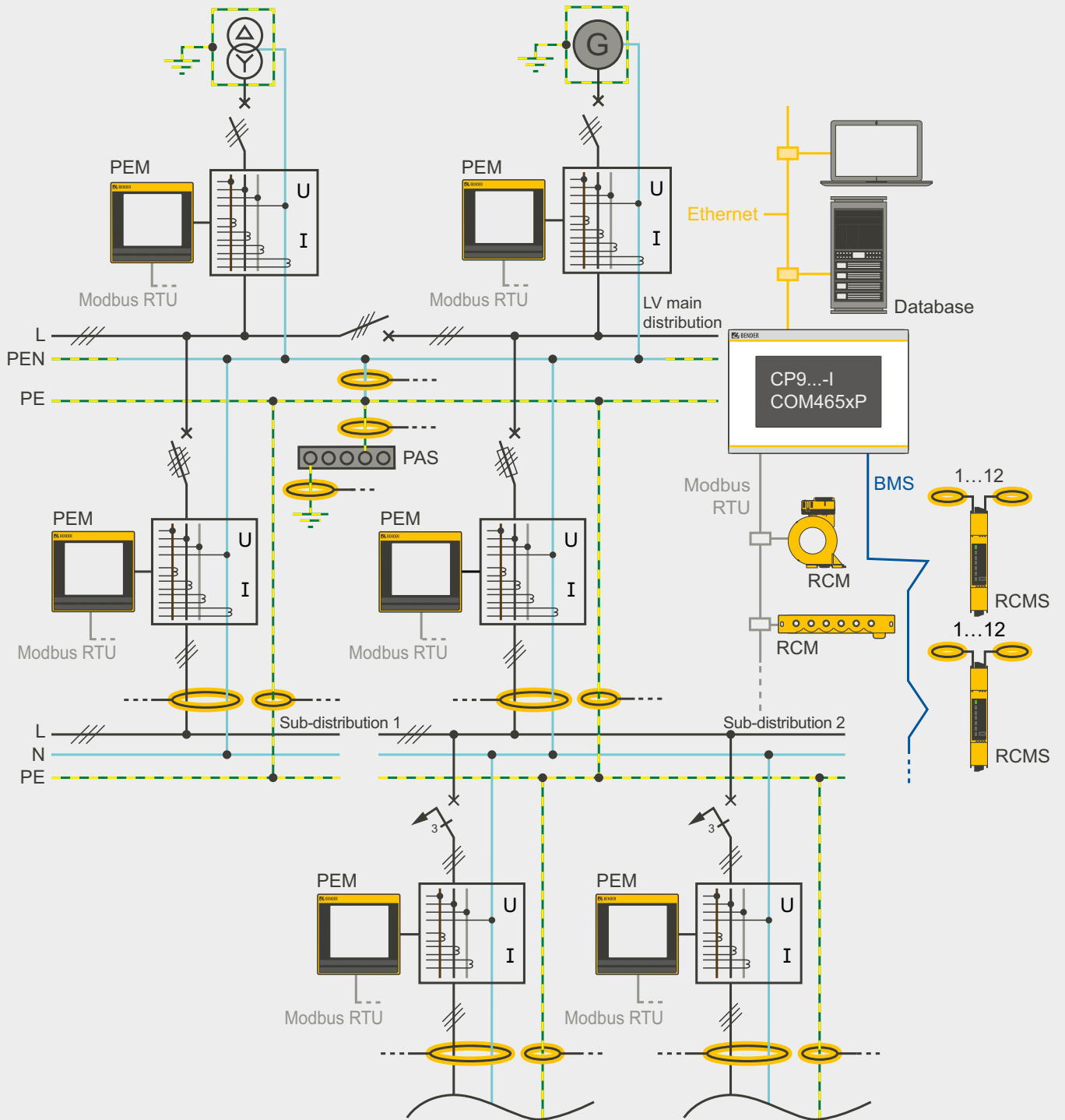

LINETRAXX® application diagram

LINETRAXX® residual current monitors for earthed power supplies (TN and TT systems)



Residual current monitors RCM, RCMA, RCMB for earthed power supply systems (TN/TT systems). Residual current monitors (RCM) are used to monitor electrical installations for residual or fault currents, display the currently measured value and report when configurable response values are exceeded. They can optionally be used for signalling and/or switching.

The main areas of application are where a disconnection is not desirable or problematic due to the electrical load structure, e. g.:

- Fire and property protection in industrial and functional buildings
- UPS systems
- Cooling systems, air conditioning systems
- Variable-speed drives
- Lighting circuits
- Medical facilities
- Safety circuits
- EDP systems and much more

Convincing advantages:

- Significant cost reduction through higher availability and minimised maintenance costs
- Increased fire and property protection
- AC/DC sensitive versions for monitoring alternating currents, pulsating and smooth DC fault currents
- Independent of waveform due to true RMS measurement (TRMS)

Distinguishing features

RCM series:

Type A residual current monitors for monitoring alternating currents (42...2000 Hz) and pulsating direct currents up to 6 mA.

RCMA series:

Type B residual current monitors for monitoring alternating currents, pulsating and smooth direct currents (0...2000 Hz).

RCMB300 series residual current monitoring modules:

Measuring current transformer and evaluator in one module for monitoring alternating currents, pulsating and smooth direct currents (0...100 kHz). With 2 changeover contacts and RS-485 Modbus RTU interface.

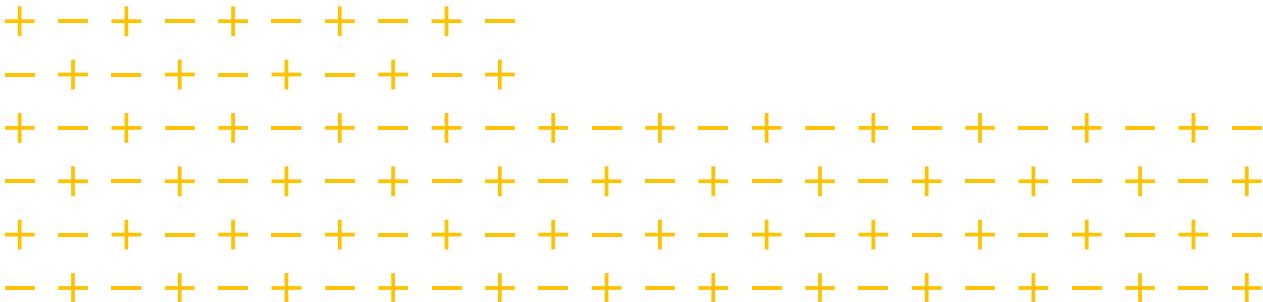

Monitors residual and fault currents wherever continuous operation must be guaranteed.



Residual current monitors



AC/DC sensitive RCMB300 series residual current monitoring modules

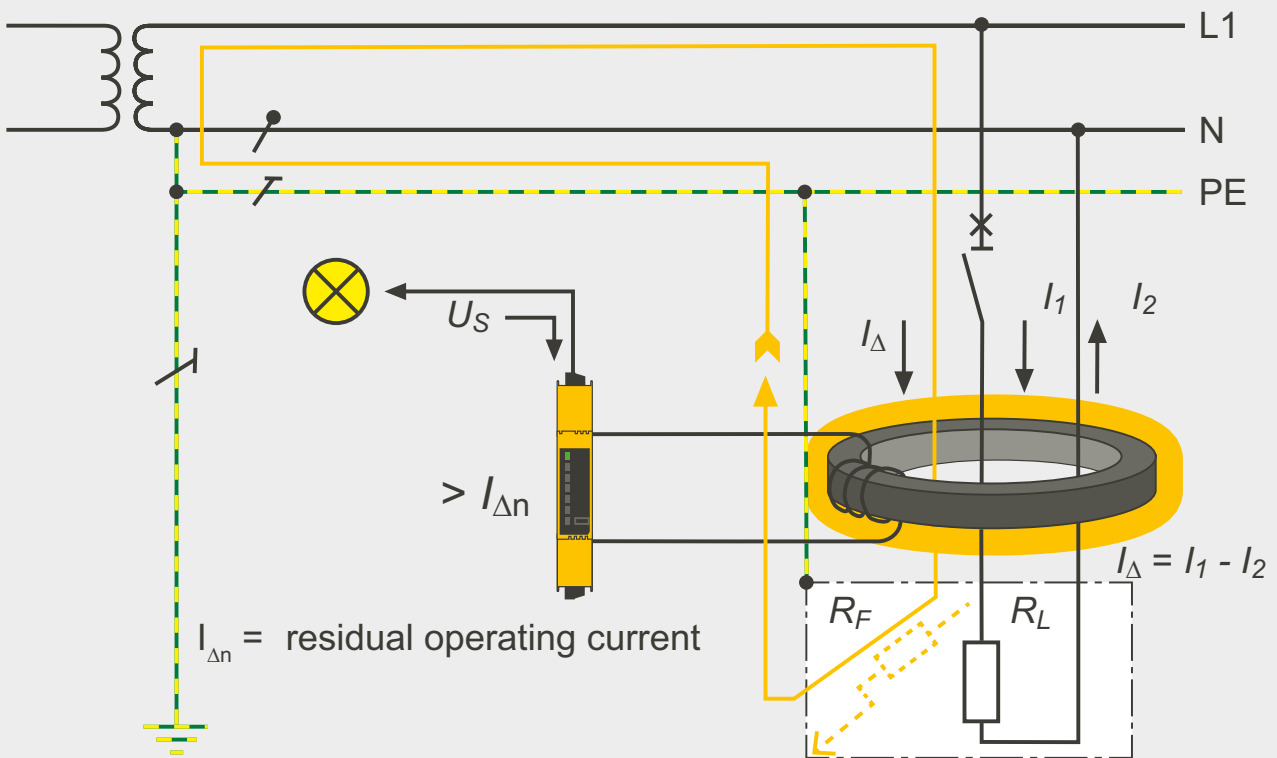

Operating principle of RCM residual current monitor

LINETRAXX® residual current monitoring systems for earthed power supplies (TN and TT systems)



For effective preventive maintenance and increased operational reliability and safety of the installation

- fault or residual currents,
- operating currents,
- stray currents, and
- currents in N and PE conductors

must be continuously monitored in power supply systems, the location of the faults quickly detected, and the service personnel must be comprehensively informed. The solution to this problem: the multi-channel residual current monitoring system RCMS410. The system is sensitive to alternating, direct pulsed or smooth currents and records the currents as a true RMS value. The measured values are stored in the history memory and data logger and are available there for evaluation. A connection to higher-level systems via Ethernet or other field bus systems is easily possible with gateways.

For installation in final circuits, the RCMS150 with 6 AC/DC sensitive channels extends the RCMS product portfolio.

Typical applications:

- Data centres, EDP systems
- Industrial, residential and functional buildings
- Office and administration buildings
- Power generation and distribution
- Communication technology systems
- Traffic engineering
- TV and broadcasting stations

Convincing advantages:

- Continuous monitoring of electrical installations in terms of the Directive 2009/104/EC and its implementations into national law (regulations regarding industrial safety and health) and the accident prevention regulations in accordance with DGUV Regulation 3
- High degree of property, fire and plant protection
- High cost-efficiency by avoiding unexpected interruptions to operation and production
- Time and cost savings through precise fault location
- Low maintenance costs through timely replacement of fault-prone components
- Continuous monitoring of EMC-friendly TN-S power supplies
- Central administration via LAN/WAN network





Multi-channel residual current monitoring system

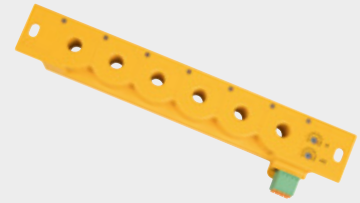

AC/DC sensitive residual current monitoring system

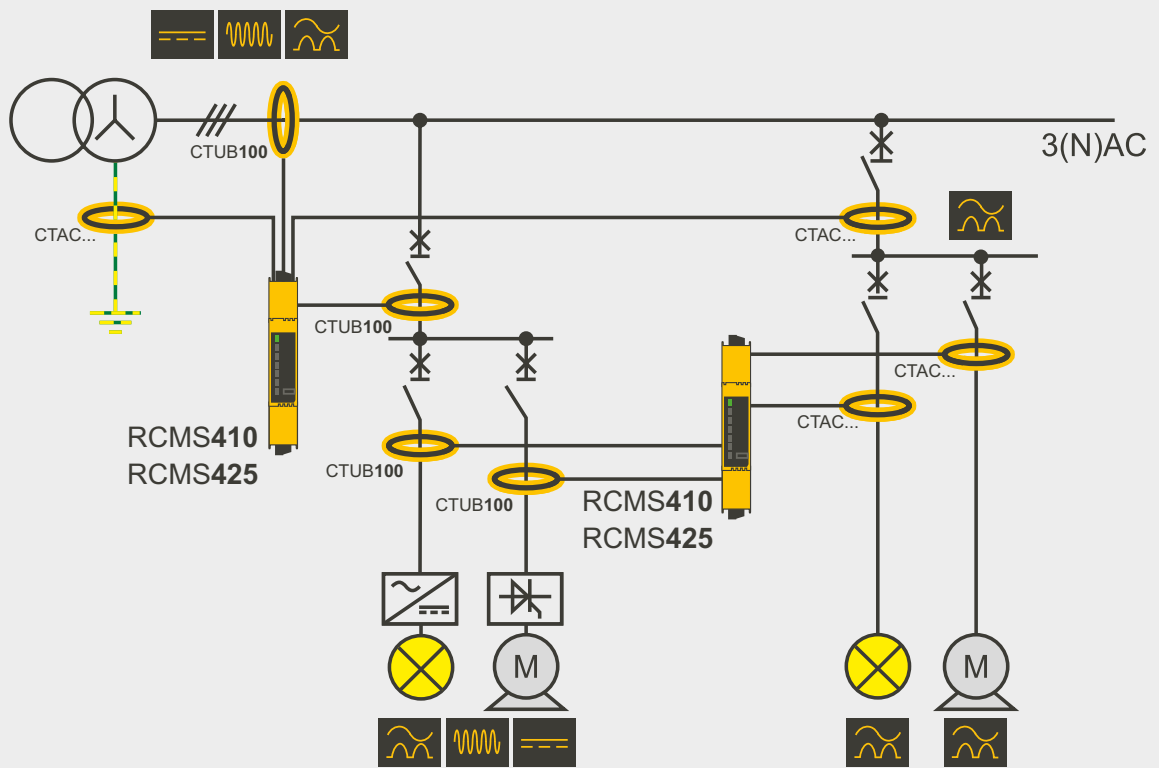

Operating principle of residual current monitoring

LINETRAXX® modular residual current device MRCD in accordance with DIN EN 60947-2 Annex M



Detection and evaluation of residual currents for protective purposes in combination with circuit breakers.



MRCD B301



MRCD B423

What does MRCD stand for?

RCD (Residual Current Device) is the generic term for all types of residual current protective devices. In addition to the well-known RCCB, RCBO and CBR (circuit breaker with residual current protection), this product group also includes the MRCD (modular residual current device). All the devices mentioned are capable of detecting a residual current and disconnecting the monitored circuit in the event of a fault. A disconnection as required by IEC 60364-4-41 takes place. Residual current devices are required or recommended in many areas (DIN VDE 0100-530, IEC 60364-5-53).

What is an MRCD?

An MRCD is a device or a combination of devices intended for the detection and evaluation of residual currents. It can be used for protective purposes. By connecting it to a switching element with isolating properties, the MRCD can trip the switching element within a very short time in the event of a fault.

How is an MRCD designed and connected?

The MRCD is available in two different variants:

- as device (detection and evaluation of the residual current combined, e.g. Bender MRCD B300 series)
- or as a combination of devices (evaluation unit and current detection unit separately, e.g. Bender MRCD B423 with CTUB100 series)

The MRCD is connected to the trigger of a switching element with isolating properties (e. g. circuit breaker). For personal and fire protection, an undervoltage release should be used; for plant protection, a shunt trip can be used.

How does an MRCD operate?

When the adjustable prewarning threshold is exceeded, a potential-free contact switches. If the set response value is exceeded, the alarm relay of the MRCD switches and activates the undervoltage release or the shunt trip of the circuit breaker.

When may an MRCD be used?

An MRCD solution can be used as protection against electric shock by automatically disconnecting the power supply in the event of a fault or as additional protection (IEC 60364-4-41). Furthermore, it can be used as a preventive fire protection measure in accordance with VDE 0100-530 (IEC 60364-5-53). In general, an MRCD solution can be used whenever the MRCD is only accessible to instructed persons or electrically skilled persons. It is therefore not suitable for domestic installations (DIN VDE 0100-530).

LINETRAXX[®] modular residual current device MRCD according to IEC 60947-2 Annex M



Example for the configuration of an MRCD module of the MRCD300 series for combined detection and evaluation of residual currents



Evaluator: MRCD301

+



Measuring current transformer: CTBC35

=



Final MRCD module

Your benefits:

- Flexibly adaptable to the installation
- Nuisance tripping is reduced
- Residual current detection by means of a measuring current transformer
 - Independent of mains voltage and frequency
 - Can be used also with high load currents
- Response values according to IEC 60364-4-41
- Adjustable time delay according to IEC 60364-4-41
- Prewarning – offers the following advantages to the system operator:
 - Early information on insulation level before shutdown
 - Prevents unplanned and cost-intensive downtimes
 - Higher operational reliability and safety of the installation

Application example:

AC/DC sensitive modular residual current device (type B) MRCD303 with an integrated measuring current transformer combined with a circuit breaker. Configurable response range 30 mA ... 3 A; can be flexibly adapted to system-related leakage currents.

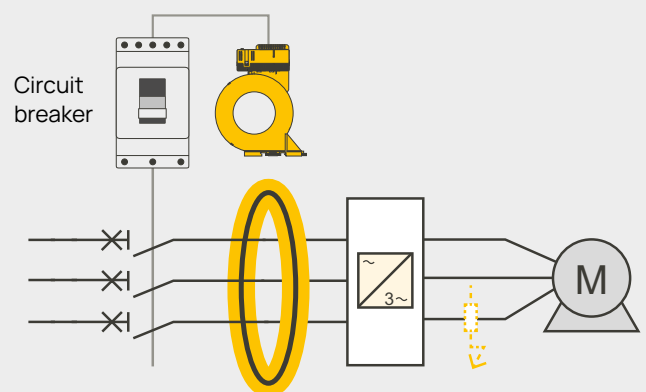

MEDICS®

The comprehensive safety solution for medical facilities



MEDICS® – for a safe and reliable power supply

MEDICS® is a comprehensive and proven system for implementing any task for a safe and reliable power supply in medical locations.

Convincing advantages:

- Standard-compliant monitoring, management and checking of the
 - normal power supply source
 - safety power supply source
 - battery-supported safety power supply
- Standard-compliant design and monitoring of medical IT systems
- User-oriented information for technical/medical personnel with clear instructions for action
- Comprehensive service and support throughout the entire life cycle of the installation
- Intelligent networking with information and communication technology – centrally on site, locally with the building management system or monitored by the manufacturer
- Additional safety through compact, ready-to-connect complete solutions with voluntary testing by TÜV Süddeutschland
- Confirmation of standard-compliant design according to DIN VDE 0100-710 and IEC 60364-7-710
- Certification of functional safety according to IEC 61508 (SIL 2)
- Retrofit for existing installations: increased safety, compliance with standards and energy saving



ATICS® transfer switching and monitoring device

Typical applications:

- Hospitals
- Sanatoriums and health resorts
- Retirement and nursing homes
- Outpatient surgery in doctors' surgeries
- Medical care centres



Alarm indicator and operator panels



Alarm indicator and test combinations



Display panels

Application diagram MEDICS®

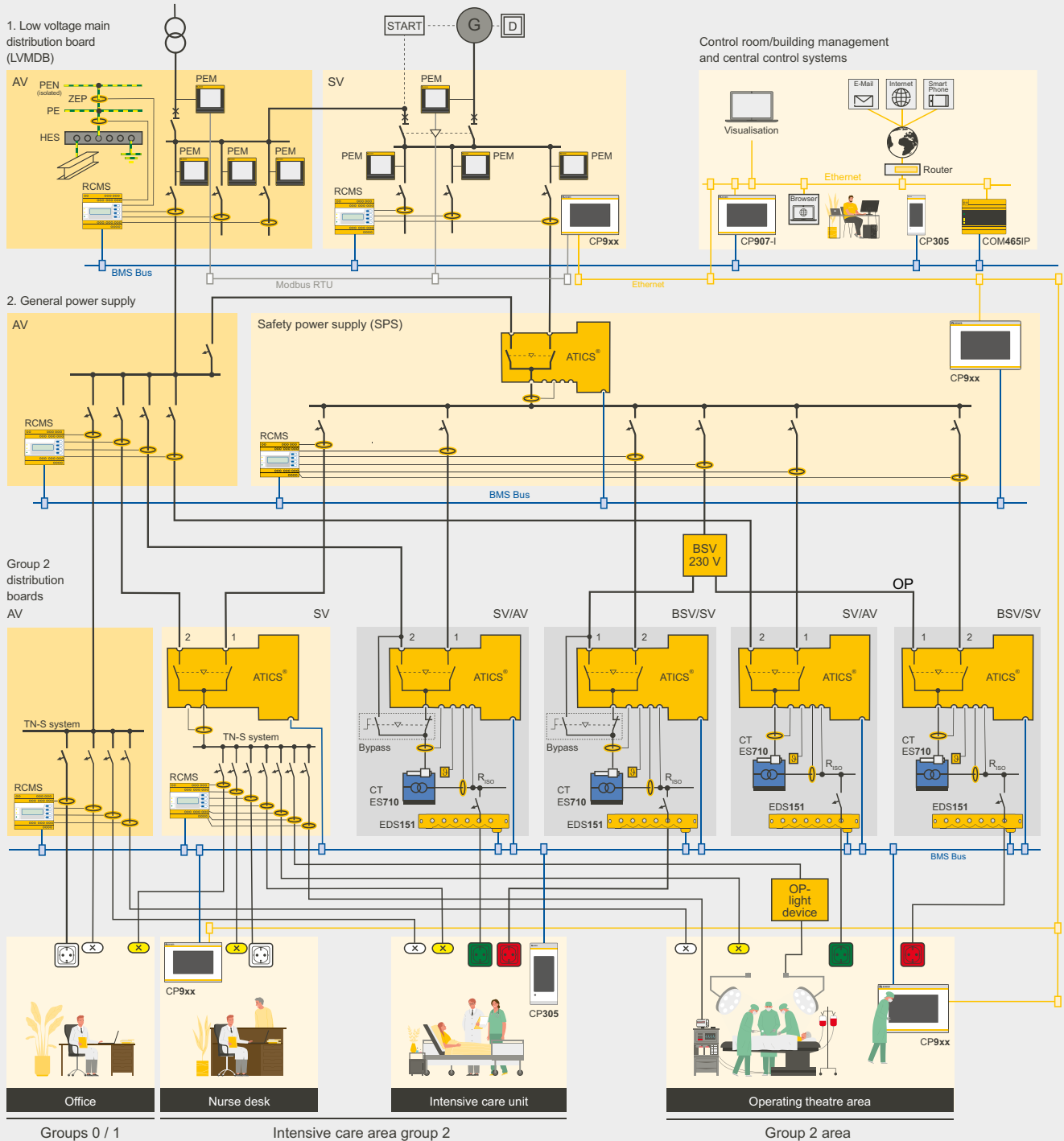

HES = Main earthing terminal	AV = Normal power supply source	PA = Equipotential bonding
ZPA = Central equipotential bonding	ZEP = Central earthing point	BSV = Battery-supported safety power supply

ATICS® transfer switching and monitoring devices



For maximum reliability when switching acc. to SIL 2.



Transfer switching and monitoring device, 2-pole



Automatic transfer switching device for safety power supplies, 4-pole

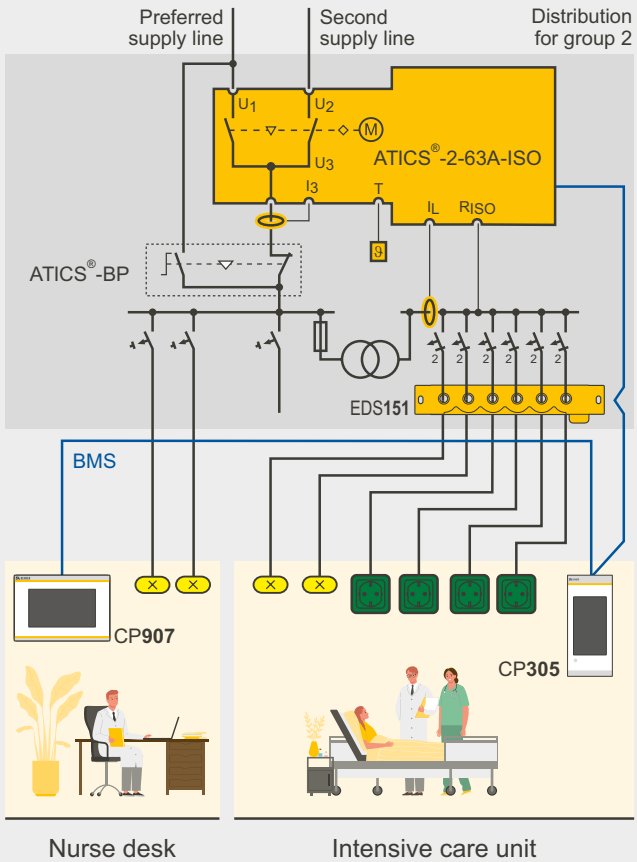
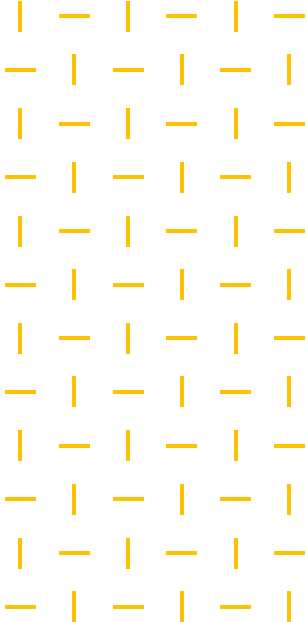

Transfer switching for intensive care units with integrated insulation fault locator (EDS) and bypass switch

ATICS®, the world's safest and most compact all-in-one transfer switching and monitoring device for safety-relevant areas and medical locations

Sensitive installations require a safe and reliable power supply even in the event of incidents. The ATICS® transfer switching devices ensure reliable switching between two independent supply lines. For maximum reliability, ATICS® was developed consistently in accordance with the guidelines for functional safety (SIL 2). The transfer switching device is perfectly suited for power supply in safety-relevant areas, e. g.

- Group 2 medical locations in accordance with DIN VDE 0100-710 (VDE 0100-710) and IEC 60364-7-710
- Emergency power supplies
- Heating, air conditioning, ventilation, cooling
- EDP, data centres
- Fire extinguishing and sprinkler systems

Convincing advantages:

- All-in-one: integration of switch disconnector and control
- Functional safety SIL 2
- Safe to operate
- Robust switch disconnector contacts
- Mechanical locking
- Manual operation directly on the device
- Certification by TÜV SÜD
- Perfect for space-saving installation/retrofit
- Convenient installation and commissioning
- Excellent communication and parameterisation capability
- Time and cost saving
- Plug-in connections
- Interruption-free maintenance owing to optional bypass switch

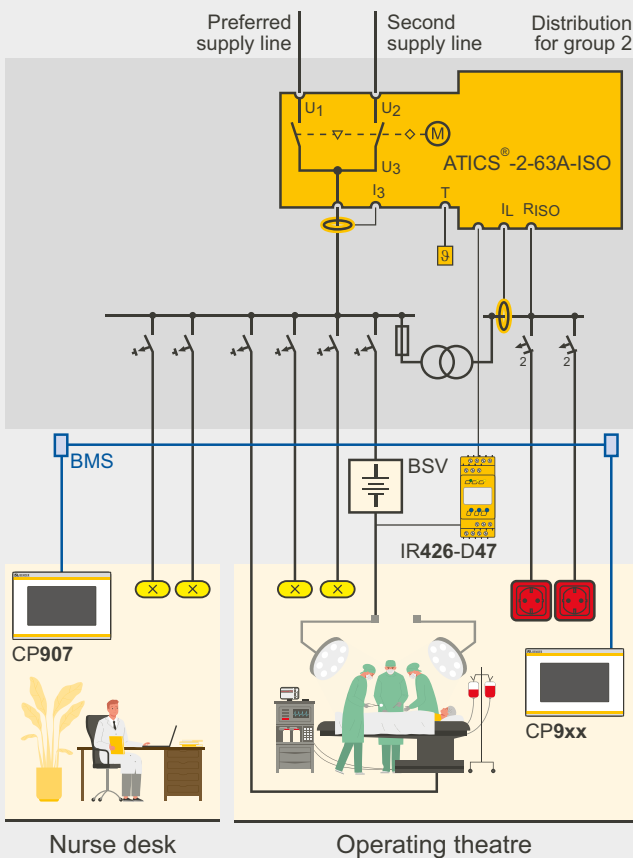

Transfer switching for operating theatres with surgical light ISOMETER®

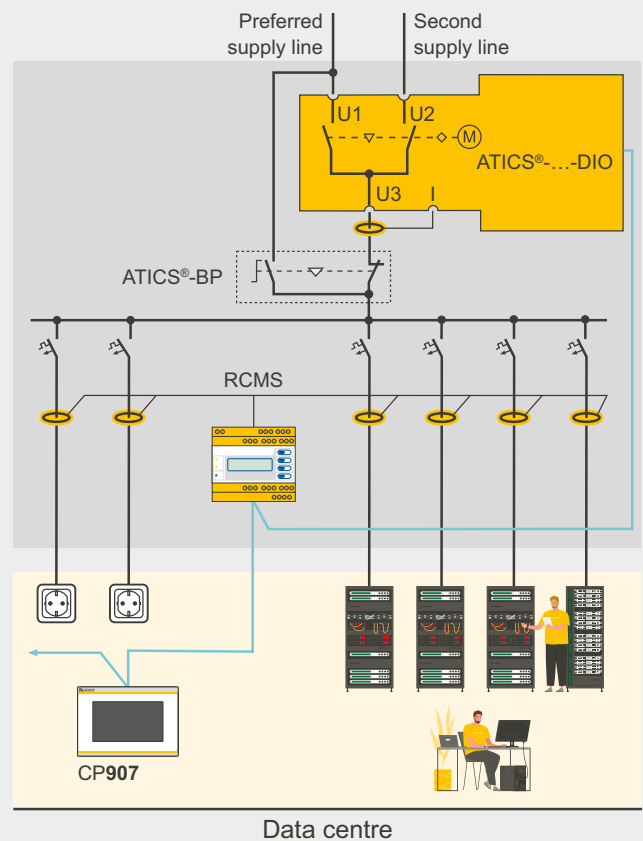

Transfer switching for safety-relevant areas with extension by RCMS residual current monitoring system

UNIMET® test systems

Safety testers for easy initial verifications, periodic verifications.



Lightweight safety tester for mobile use



IEC 60364-6 testing and safety tester for beds

Test systems for testing the electrical safety of medical electrical equipment and general electrical equipment

Electrical safety is an essential aspect when using medical electrical equipment and mobile equipment. In order to protect the user from hazards caused by electric current, various regulations and laws make regular testing mandatory.

The safety testers of the UNIMET® series make it easy to perform initial inspections at the manufacturer's premises, tests and periodic verifications before commissioning, or tests after maintenance and repair.

Standard-compliant tests in accordance with:

- IEC 60601-1, 3rd edition (optional)
- IEC 62353:2014
- DIN VDE 62353 (VDE 0751-1):2015-10
- ÖVE/ÖNORM EN 62353:2009-01
- DIN EN 50678 (VDE 0701):2021 02
- DIN EN 50699 (0702):2021 06

Convincing advantages:

- Simple operation through user guidance
- Schedule updates and multi-client capability
- Time saving through automatic test sequences
- Regulation-based classification of the DUT (device under test)
- USB printer interface and TFT display, simple documentation via printer or PC

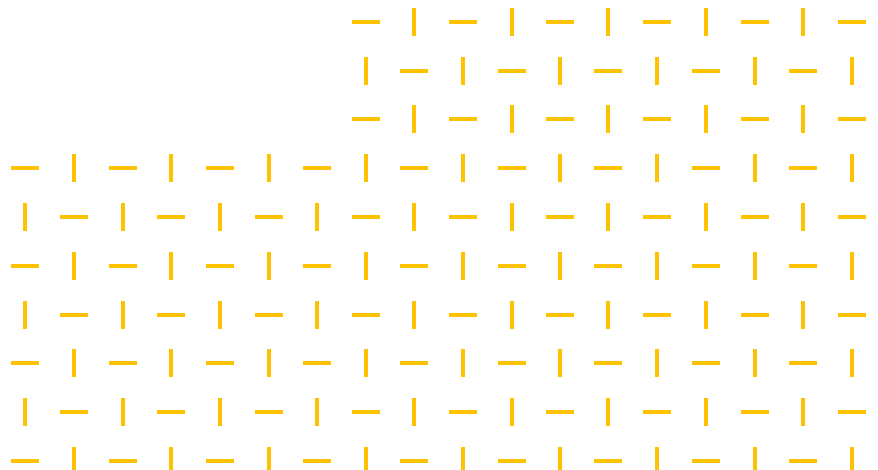



Service safety tester

COMTRAXX® system components

Central display, alarm indicator and operator panels

Access to all required information – always and everywhere via PC.



Display, alarm indicator and operator panels – web server and local display



Condition monitor with web server

Display, operation, communication – the overview of your installation

Despite all the technology installed – there are people at decisive places who need the right information at the right time and in the right place for precise action. The CP9...-I condition monitor meets this crucial requirement. It is the central display, alarm indicator and operator panel from which a wide variety of devices, from ISOMETER® and RCMS to power quality monitoring, can be uniformly operated and parameterised. Operation is intuitive and supported by an interactive help system. This is possible thanks to a built-in touch screen and the integrated web server.

In addition, the COMTRAXX® CP9...-I series condition monitors and the COM465IP (COM465IP/COM465DP) can also be used as data suppliers for higher-level systems.

Convincing advantages:

- Overview of the entire electrical installation
- Active signalling of alarms
- Simple, direct access to all details of the devices used
- Support for fault analysis
- Easy documentation of measured values and device parameters
- Customised visualisation
- Overview of several systems
- Information access always and everywhere via PC
- Integration of equipment from third-party manufacturers
- Future proof and sustainable due to improving and expanding of functions through software updates
- Different display variants available

A wide range of solutions:

- Use of existing IT infrastructure
- Provision of messages and measured values for higher-level systems

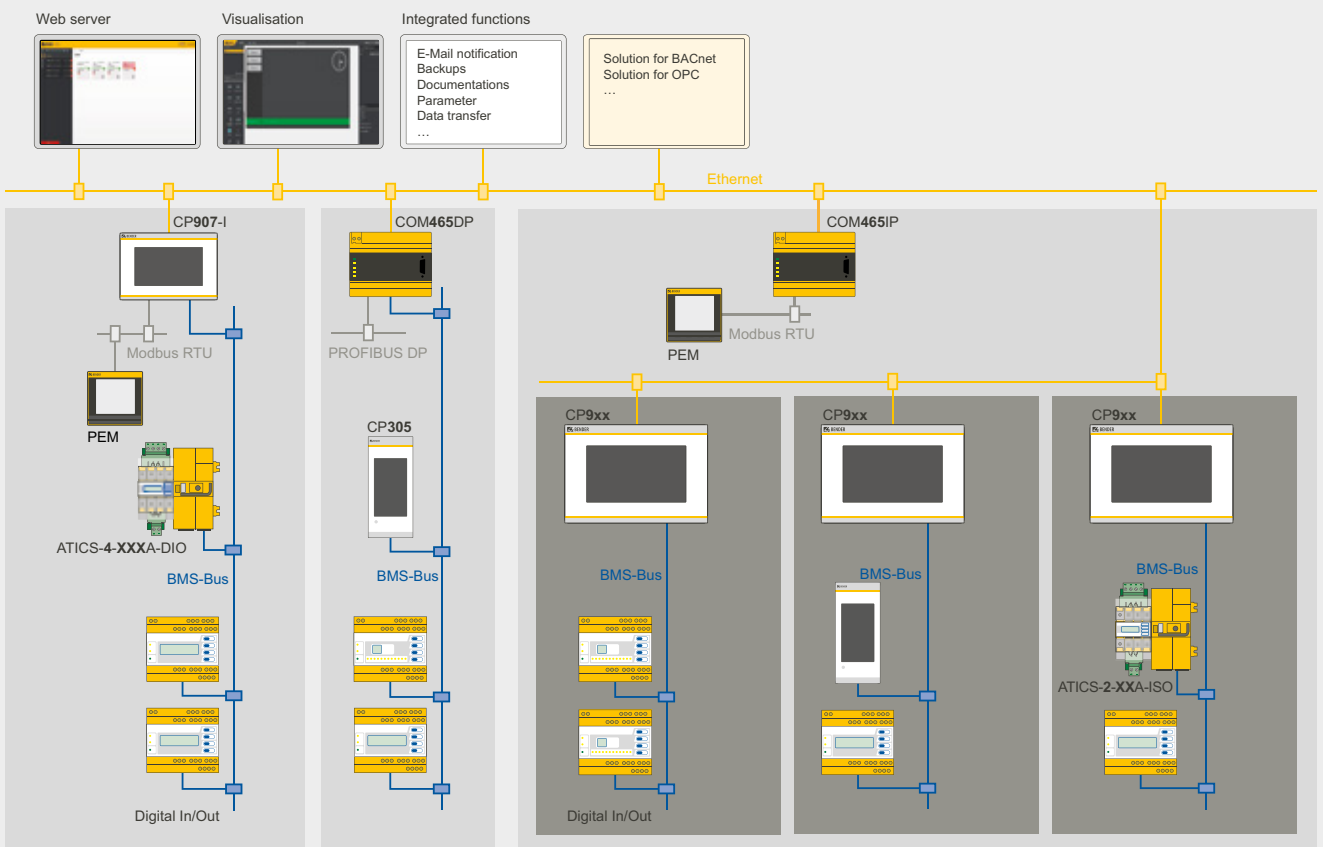

Communication solutions

Charging technology for electric and hybrid vehicles

Smart charge controllers for AC charging stations and wallboxes

The intelligence of an AC charging station or an AC charging infrastructure is largely determined by the charge controller used. A smart charge controller has the primary task of controlling and monitoring the charging process of an electric vehicle.

The most important features include communication with a backend system and the corresponding authorisation of users as well as the efficient distribution of load currents by means of dynamic load management to prevent an overload of the existing AC system.

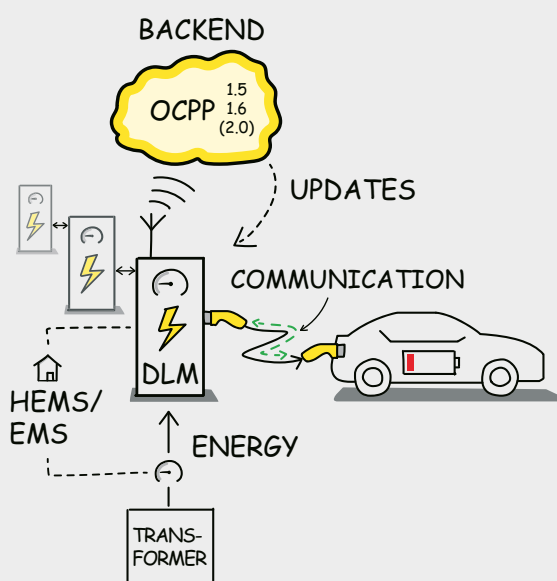

Integrated dynamic load management (DLM)

Possible applications:

- Individual charging points or wallboxes in public, semi-public, or private areas
- Networked charging infrastructures in public and semi-public areas

Convincing advantages:

- Integrated dynamic load management (DLM) for up to 250 electric vehicles
- Compliance with German calibration law
- Patented 6 mA DC residual current monitoring acc. to IEC 62955
- Integrated emergency unlocking (plug at charging point)
- Integrated 4G modem and Ethernet interface
- Regular software updates
- Power line communication (PLC) acc. to ISO 15118
- Suitable for various meter types
- OCPP 1.5 and 1.6 (JSON and SOAP) compliance
- User authorisation modules (RFID, Giro-e)
- 230 V relay for contactor control
- Modbus connection to energy management systems (KNX, EEBUS)
- USB interfaces for peripheral expansion and service (analysis and software updates)
- Additional I/O interfaces



Charging technologies that can be tailored precisely to the needs of the user

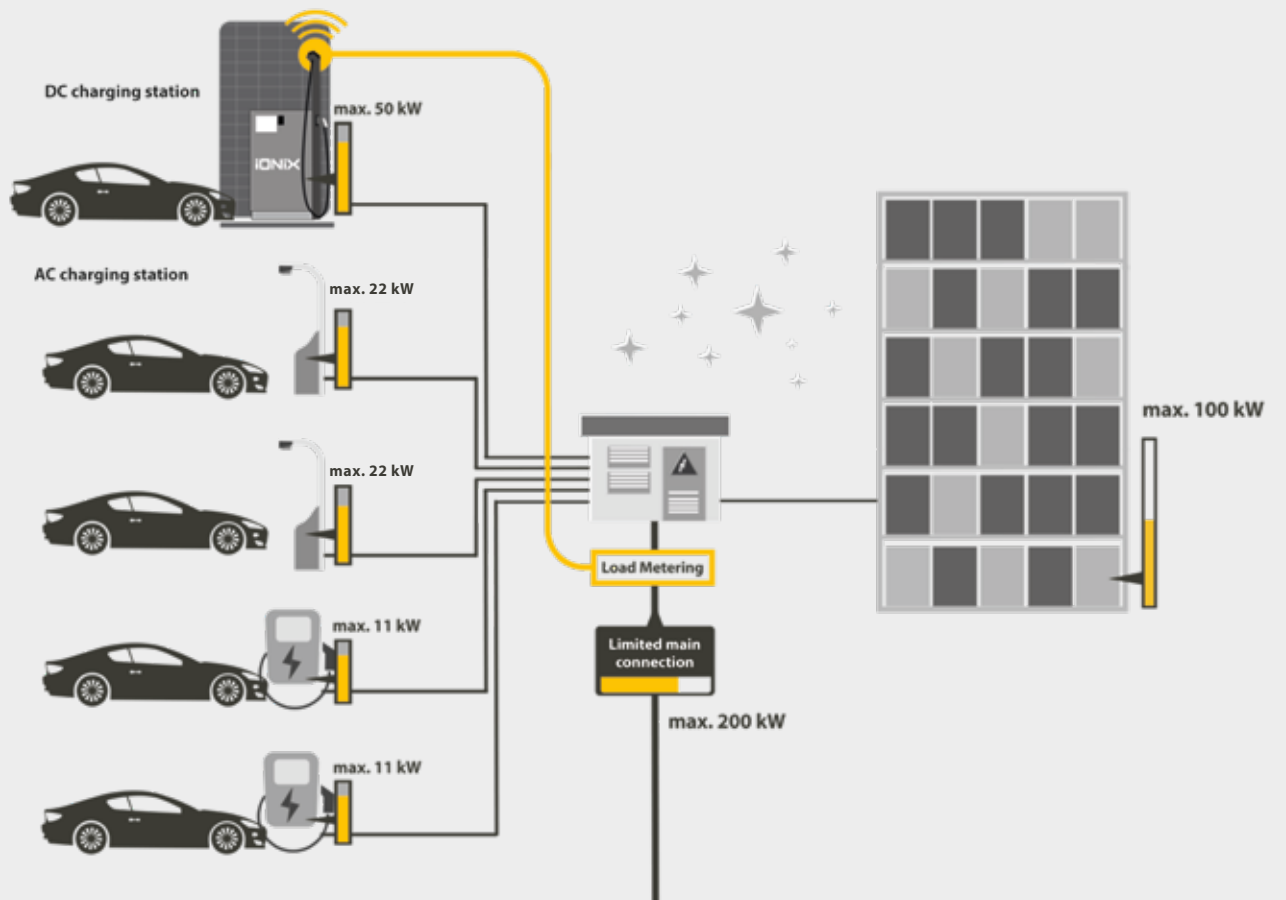

Typical application DLM

Insulation monitoring for vehicles

Making electric and hybrid vehicles safer

Continuous insulation monitoring for electric and hybrid vehicles

Continuous insulation monitoring between the active HV conductors and the vehicle chassis is prescribed by standards and can save lives. Bender insulation monitoring reliably reports insulation faults despite the high interference from motor control processes, acceleration, vibration, etc.

Typical applications

- Electric and hybrid vehicles
- Commercial vehicles
- Buses
- Agricultural machines
- Special vehicles (racing, electric boats, flight taxis)

Convincing advantages:

- Monitoring of the complete drive system (DC and AC side)
- E1 certification
- Voltages of DC 0...1000 V
- Active measurement method
- PWM or CAN interface

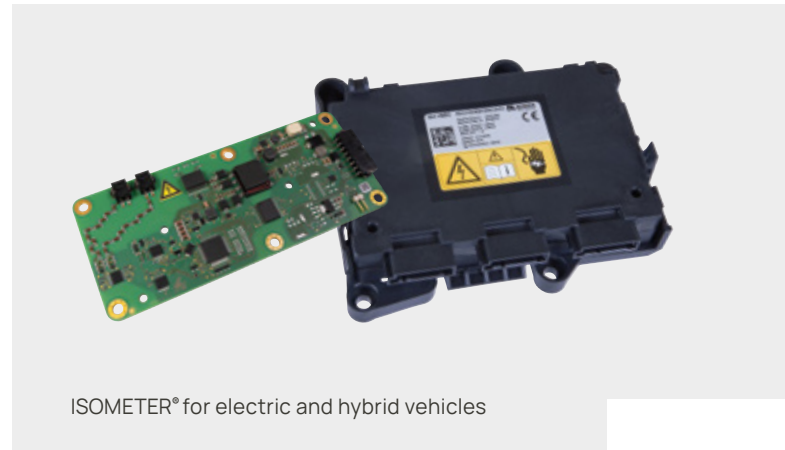

ISOMETER® for electric and hybrid vehicles

- Determination of the insulation resistance when the system is disconnected from the mains
- Measured insulation resistance available via interface
- Configurable response values/profiles for warning/error
- Quick initial determination of the insulation resistance
- PCB and enclosure variants
- Separability from the HV system
- Support of system analysis (voltage, capacitance, asymmetry,...)
- Earth connection monitoring

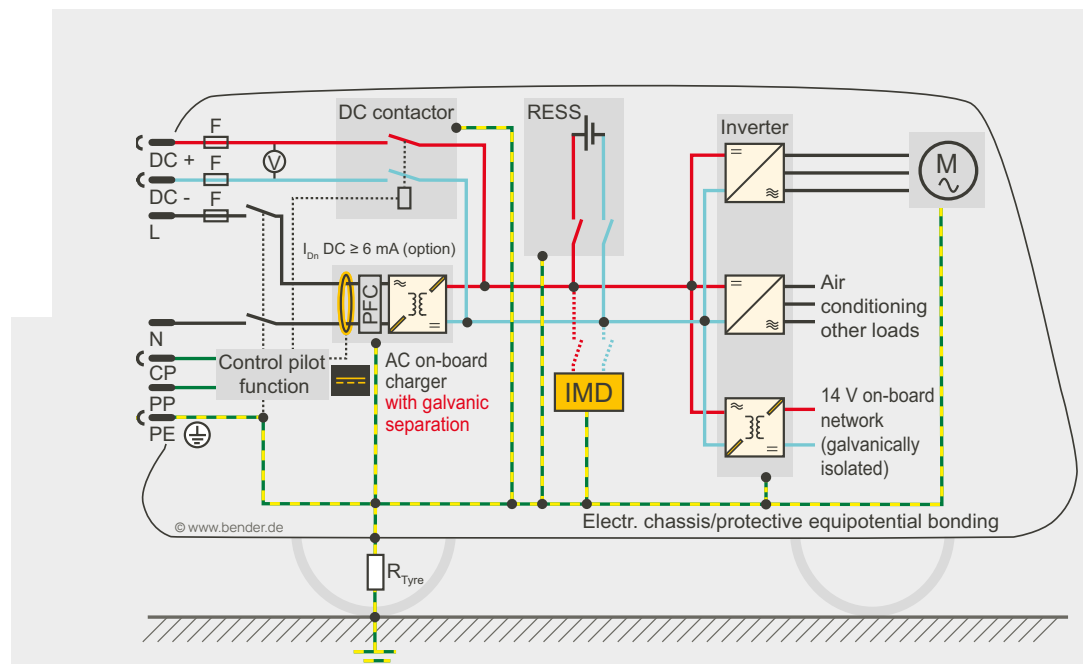

*(IMD) = Insulation Monitoring Device

Infrastructure sensors for AC and DC charging

Safe use of charging technology for electric vehicles



Residual current sensor technology for AC charging



Insulation monitoring for DC charging stations

Residual current sensors for AC charging in IC-CPDs (mode 2) and charging stations/wallboxes (mode 3).

Residual currents are continuously monitored during AC charging using the patented measurement method so that the charging process is interrupted as soon as there is any danger to persons.

Due to their compact design, the residual current sensors are ideally suited for space-saving use in any charging infrastructure.

Convincing advantages:

- Cost-effective solution, since it can be used with an RCD type A. No RCD type B required
- Space-saving: separately integrated electronics and converter
- Can be combined with various measuring current transformers
- Compact construction and robust design
- Implemented self test function
- High insensitivity to external interferences

Insulation monitoring devices for direct current (DC) charging (mode 4).

DC charging stations are designed as unearthed systems and must therefore be equipped with an insulation monitoring device. Due to the high voltages and currents involved, the safety of persons plays a very important role. The ISOMETER® can be used in both systems:

- Combined Charging System (CCS)
- CHAdeMO standard

Convincing advantages:

- For DC charging systems up to 1000 V DC
- Monitoring of the complete charging circuit: from the charging station to the electric vehicle
- Active measurement method according to IEC 61557-8
- Basic parameterisation 100/500 k Ω (error/warning)
- Modbus RTU interface
- Signal relay

POWERSCOUT®

Maximum transparency for your electrical installation



Web-based software solution POWERSCOUT®

Moisture, ageing, dirt, mechanical damage, or faults due to the impact of current, voltage, and temperature cause malfunctions in every electrical installation. The web-based software solution POWERSCOUT® helps to detect malfunctions at an early stage and to eliminate the causes in an economically reasonable way. This guarantees high safety of the installation and high operational reliability and reduces costs.

Analysis – as individual as your system– as simple as possible

Predictive maintenance prevents downtimes, reduces costs and personnel expenditure. POWERSCOUT® informs you about the condition of your electrical installation at all times, since the informative visualisations with flexible dashboards can be retrieved via any display device: smartphone, laptop, computer. On request, POWERSCOUT® sends you these graphically processed reports at specified intervals.

Continuous monitoring instead of random tests

Manual data acquisition is time consuming, error-prone and only provides the results of a spot check. POWERSCOUT® gives you an insight into the entire data of your installation at any time, since all measured values are automatically and continuously saved. Your data is archived reliably and remains available for years.

Basis for periodic verification as per IEC 60364-6

The automated POWERSCOUT® report on residual currents forms the basis for measuring without switch-off for the periodic verification. In order to maintain the correct status, for electrical installations and stationary electrical equipment periodic verifications must be carried out.

This can be ensured, for example, by means of continuous monitoring of the installation carried out by electrically skilled personnel. In this case, it is a smart move to rely on continuous monitoring with multi-channel residual current monitoring systems (RCMS) and an evaluation (COMTRAXX® series) adapted to the system. The automatic POWERSCOUT® reports based on this monitoring make it easier for the electrically skilled person in charge to adjust the time limits for the insulation test within the context of the periodic verification.

Analysis

- Continuously recording insulation values
- Recognising correlations and optimising processes
- Cross-system evaluation possibilities
- Access from any place
- Support for investment decisions

Predictive maintenance

- Higher availability
- Continuous monitoring

- Early detection of gradually developing insulation faults
- Early detection and reporting of short-time insulation degradation
- Lower costs incurred due to unexpected malfunctions and shutdowns

Report

- Historical comparisons
- Safe storage of measured values
- Event and alarm statistics

Support during all stages – All-round service for your installation remote, by telephone, on site

From planning to modernisation – Our extensive know-how is at your disposal during all project phases.

Furthermore, with our first-class service we guarantee maximum safety for your electrical installations. We offer services ranging from support over telephone to repairs and on-site service – with modern measuring devices and competent employees.

Be on the safe side:

- High availability of your installation thanks to fast reaction to fault messages
- Increased profitability of your capital expenditure (CapEx) via optimised maintenance processes
- Targeted operating expenditure (OpEx) due to reduced downtimes and shorter service visits
- Support for your predictive installation monitoring and regular checks of your installation/power quality/monitoring devices

- Automatic checking, analysis, correction, new settings/updates
- Competent assistance with changes of parameter settings and updates

Bender Remote Assist

Bender Remote Assist supports you via remote access, high-quality service and advice for your challenging task of ensuring consistently high safety in your installations.

For many service operations, fault eliminations but also analyses and checks can be carried out remotely – without the expense of time and money that an on-site visit by a technician entails.

This fast, efficient help and advice provided by our network of experts allows the highest possible availability of your system.

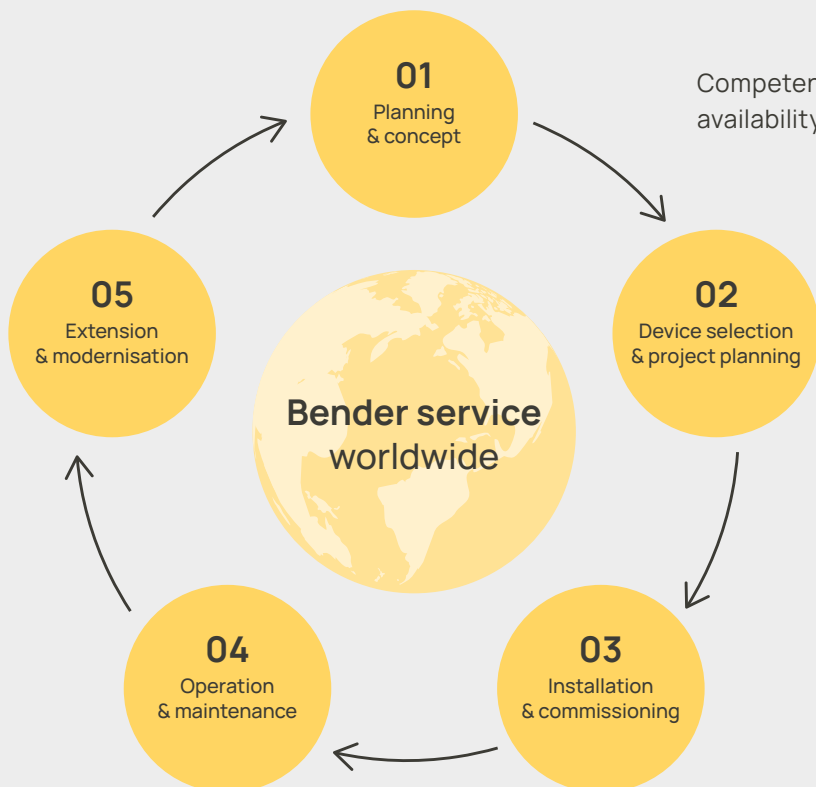

Competent service for maximum safety and high availability of your installation



Fault location – made easy

With portable fault location systems, existing insulation faults can be quickly located. They are the best alternative if no stationary insulation fault location systems are available.

Retrofit

Untested devices and installations pose a safety risk



Is your installation still state-of-the-art?

No electrotechnical installation is immune to the effects of time. Whether it is decreasing operational reliability, changing legal conditions or rising energy costs: Adapting to the current state of the art is indispensable. Typically, products for power quality monitoring and fault location are retrofitted.

Risk assessment according to Directive 2009/104/EC and its implementations in national law: Does your currently installed monitoring system detect symmetrical and asymmetrical insulation faults in the IT system?

Symmetrical and asymmetrical insulation faults represent a high risk potential. With Bender insulation monitors, your systems are continuously monitored, insulation faults are detected and reported. Bender insulation monitors comply with IEC 61557-8.

Bender provides flexible solutions for retrofitting projects. Modern monitoring methods can also be integrated in old installations even during ongoing operation. Retrofitting is made possible by devices such as split-core current transformers, as the power supplies do not have to be switched off and cable systems do not have to be disconnected for the retrofit.

Update your electrical installation to the latest state of the art!

Your advantages

- Well prepared for the standards of tomorrow
- Compliance with legal requirements
- Increased availability
- Update to the latest safety standard
- Cut costs and reduce energy consumption
- Ensure spare parts supply in the long term

Systematic and efficient modernisation at low cost!

Let us check your electrical installations and provide you with suggestions for the next steps.



Bender. Making your world safe.

Our world is networked on a global scale; it is digital, mobile and highly automated. And no matter whether in hospitals, in industry, inside or outside buildings, in power stations, in trains, underwater or underground: it never stands still and it is more dependent than ever on a reliable and, above all, safe electrical power supply.

And exactly that is our mission: We make electricity safe. With our technologies, we ensure that electricity is permanently available and guarantee faultless protection against the hazards of electric shock. We protect buildings, installations and devices, and therefore your investments and plans. But what we primarily protect are the lives of the people behind the electrical installations.



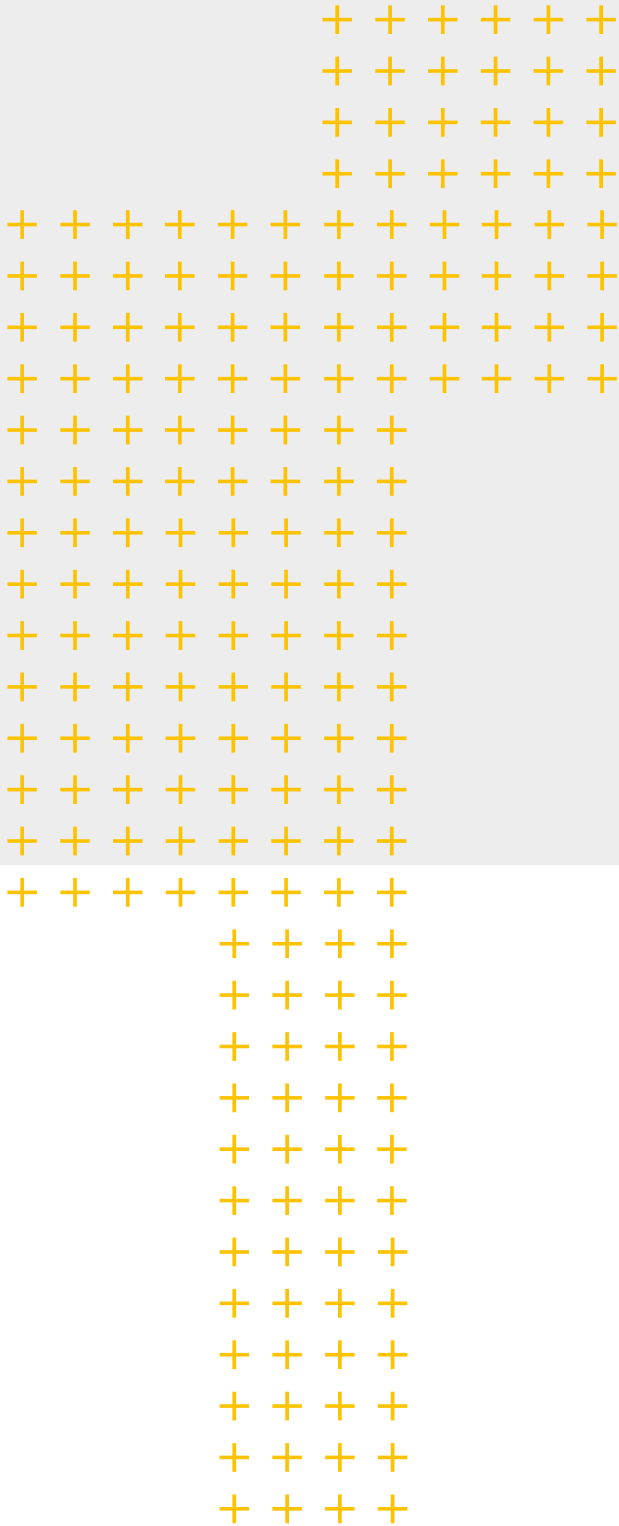

Bender GmbH & Co. KG

Londorfer Straße 65
35305 Grünberg
Germany

Tel.: +49 6401 807-0
info@bender.de
www.bender.de

Photos: AdobeStock (© industrieblick , © biletstiyevgeniy.com,
© Clayton D/peopleimages.com, © malp, © Jose Luis Stephens,
© Gorodenkoff Productions OU, © totojang1977 , © Southworks,
© koldunova, © kbarzycki , © Nancy Pauwels, © TeacherPhoto,
© 2ragon , © agnormark), 125RF (© stefan77) and Bender archives.

2105de /03.2025 / © Bender GmbH & Co. KG, Germany
Subject to change! The specified standards take into account the
version valid at the time of printing.

